

Millermatic[®] 211 Auto-Set[™] with MVP[™]

Issued January 2009 • Index No. DC/12.54

MIG Arc Welding Power Source,
Wire Feeder and Gun Package



Quick Specs

Light Industrial Applications

Light Fabrication
Maintenance and Repair
Garage/Body Shop
Farm/Home

Processes

MIG (GMAW)
Flux Cored (FCAW)

Input Power

230 V, 25 A, 60 Hz, Single-Phase
120 V, 20 A, 60 Hz, Single-Phase

Rated Output 150 A at 23.5 VDC, 30% Duty Cycle (230 V)
90 A at 20 VDC, 20% Duty Cycle (120 V)

Amperage Range 30–210 A

Max. Open-Circuit Voltage 34

The Power of Blue.[®]

Auto-Set[™]: The right settings automatically —

- Set the wire diameter, a blue light shows that **Auto-Set[™]** is activated
- Dial in the thickness of what you're welding
- Start welding with the exact parameters you need!

Infinite voltage control gives you the flexibility to manually set the machine when welding aluminum, stainless steel, or anytime you want to set your own parameters on mild steel.

Welds thickest material in its class!

The Millermatic[®] 211 Auto-Set[™] with MVP[™] has the highest output in its class. It can weld from 24 ga – 3/8 in (0.8–9.5 mm) mild steel in a single pass on 230 V.

Spool gun ready out of the box!

Finally a reliable and economical way to weld aluminum. Hooked up to a Millermatic[®] 211 Auto-Set[™] with MVP[™], the new Spoolmate 100 Series spool gun allows you to weld from 18 ga – 3/8 in aluminum.

Smooth-Start[™] patented technology provides a smooth, spatter-free start. It's the best-starting machine in the small MIG machine category. No pop gun starts and virtually no spatter to clean up.

MILLER EXCLUSIVE! Multi-voltage plug (MVP[™]) allows you to connect to common 120 or 230 V power receptacles without the use of any tools — simply choose the plug that fits the receptacle and connect it to the power cord.

Durable cast aluminum drive system incorporates dual-groove quick-change drive roll and spring-loaded tension arm with calibrated tension knob, all designed to make set up easier and faster.

New!



TRUE BLUE[®]
3 YR. WARRANTY

Welder is warranted for 3 years, parts and labor. Original main power rectified parts are warranted for 5 years.
Gun warranted for 90 days, parts and labor.

Comes Complete With:

- Power source
 - 6 ft (1.8 m) power cord and MVP[™] plugs
 - 10 ft (3 m) M-10 MIG gun and cable assembly
 - 10 ft (3 m) work cable and clamp
 - Smith[®] Argon and AR/CO₂ mix regulator/flow gauge with hose
 - Spool of Hobart[®] .030 in (0.8 mm) solid wire
 - Two contact tips for .030 in (0.8 mm) wire and two contact tips for .035 in (0.9 mm) wire
 - Dual groove quick-change drive roll for .024 in (0.6 mm) or .030/.035 in (0.8/0.9 mm) wire
 - Factory-installed gas solenoid valve
 - Set-up and operation CD
 - Information/settings chart
 - Material thickness gauge ▶
- #229 895

Note: Shielding gas and safety equipment not included.



Miller's exclusive "Tip Saver" short circuit protection shuts down output when tip is shorted to the work. Extends contact tip life and protects internal components from damage. **Trigger reset** permits quick reset at gun rather than unit.

Cable management built into the handle.

Thermal overload protection shuts down unit and activates **over temperature light** if airflow is blocked or duty cycle is exceeded. Automatically resets when fault is corrected and unit cools.

Uses 4 or 8 in (102 or 203 mm) spools and can be set up to weld with wire sizes .024–.035 in (0.6–0.9 mm) mild/stainless steel and .030–.045 in (0.8–1.2 mm) flux cored.

MADE IN **USA**



Miller Electric Mfg. Co.
An Illinois Tool Works Company
1635 West Spencer Street
Appleton, WI 54914 USA

International Headquarters
Phone: 920-735-4505
USA FAX: 920-735-4134
Canadian FAX: 920-735-4169
International FAX: 920-735-4125

Web Site
www.MillerWelds.com



Specifications (Subject to change without notice.)



Rated Output	Amperage Range	Max. Open-Circuit Voltage	Amps Input at Rated Output, 60 Hz				Wire Type and Diameter	Wire Feed Speed	Dimensions	Net Weight	Ship Weight
			120 V	230 V	KVA	KW					
90 A at 20 VDC 20% Duty Cycle	30–140 A	30	20	—	2.9	2.5	Solid/Stainless Steel: .023–.035 in (0.6–0.9 mm) Flux Cored: .030–.045 in (0.8–1.1 mm) Aluminum: .030–.035 in (0.8–0.9 mm)	60–460 IPM (1.5–11.7 m/min)	H: 15-3/4 in (400 mm) W: 10-5/8 in (273 mm) D: 17-1/2 in (444 mm)	74 lb (33.6 kg)	87 lb (39.5 kg)
150 A at 23.5 VDC 30% Duty Cycle	30–210 A	34	—	24.3	5.5	4.8					

Certified by Canadian Standards Association to both the Canadian and U.S. Standards.

Control Panel

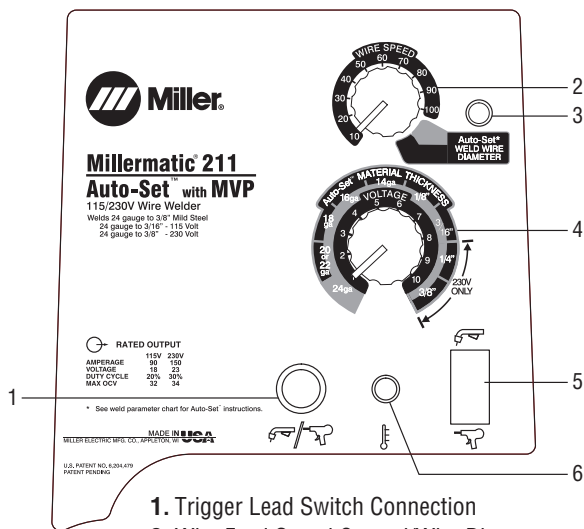

1. Trigger Lead Switch Connection
2. Wire Feed Speed Control/Wire Diameter
3. Auto-Set Light
4. Voltage Control/Material Thickness
5. Gun Select
6. Over Temperature Light

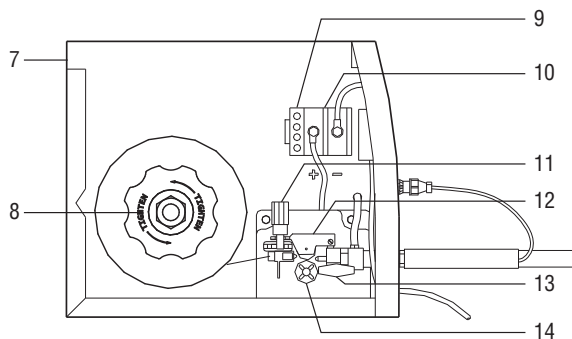

7. Power Switch
8. Plastic Hub with Retaining Ring for 8 in Spools (shaft also accepts 4 in spools)
9. Storage Holes for Spare Tips
10. Polarity Changeover Terminals
11. Calibrated Tension Knob
12. Springloaded Tension Arm
13. T-Knob (secures torch)
14. Dual Groove Quick-Change Drive Roll

Performance Data

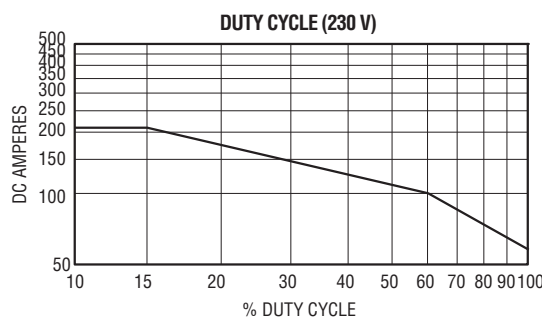
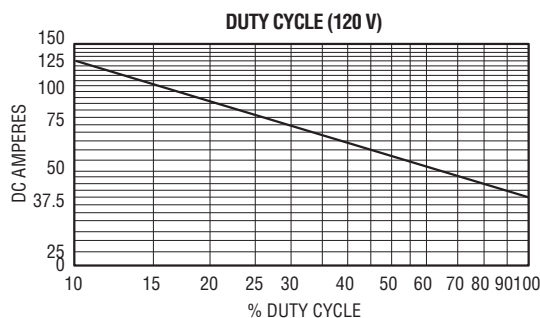
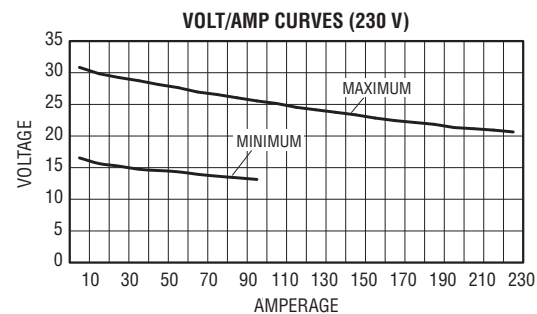
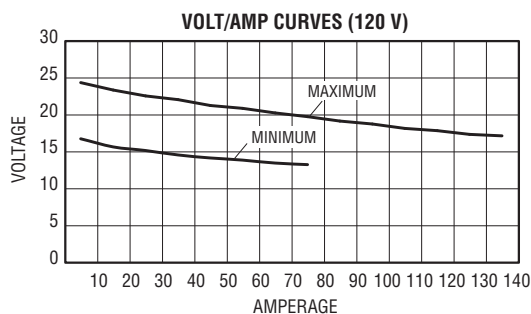

Genuine Miller Accessories



Spoolmate™ 100 Series Spool Gun #300 371

Direct connect spool gun for all Millermatic 140, 180, 211 and Passport Plus models. Handles .030–.035 in (0.8–0.9 mm) aluminum and .023–.035 in (0.6–0.9 mm) steel/stainless steel wires. Rated at 135 amps, 30% duty cycle. Includes 12 ft (3.7 m) cable assembly and custom carrying case.

M-10 Replacement Gun #195 605

10 ft (3 m). Shipped with liner #194 011.



Millermatic Protective Cover #195 149



Running Gear/ Cylinder Rack #770 187

Heavy-duty construction. Convenient handle on front with cable holders. For gas cylinders no larger than 7 in (178 mm) diameter, maximum weight 100 lb (45 kg).



Small Running Gear/Cylinder Rack #300 425

Durable construction. For gas cylinders no larger than 7 in (178 mm) diameter, maximum weight 75 lb (34 kg).

Purchase the Millermatic 211 Auto-Set with MVP package (#907 422-01-1) and receive Millermatic 211 Auto-Set with MVP and Small Running Gear/Cylinder Rack (#300 425) packaged together!

Consumables (Order from Miller Service Parts.)

For M-10 Gun



Contact Tips

- #087 299 .024 in (0.6 mm)
- #000 067 .030 in (0.8 mm)
- #000 068 .035 in (0.9 mm)
- #000 069 .045 in (1.2 mm)



Contact Tip Adapter #169 716



Replacement Liners

- #194 010 .024 in
- #194 011 .030–.035 in (standard)
- #194 012 .035–.045 in



Nozzle #169 715

1/2 in (13 mm) diameter orifice. Nozzle flush with contact tip (standard).

Spot Nozzles

- #176 237 Flat
- #176 239 Inside corner
- #176 241 Outside corner



Gasless Flux Cored Nozzle #226 190

For use with self-shielding flux cored wires. Improves visibility, eases access in tight corners, protects tip adapter/gas diffuser from spatter and from shorting to the work piece. For use with M10 and M15 torches.



Drive Rolls — Quick Change

Dual Groove, V-Smooth #220 179

For .024, .030 and .035 in (0.6, 0.8 and 0.9 mm) wire.

Dual Groove, V-Knurl #202 926

For .030/.035 in (0.8/0.9 mm) or .045 in (1.2 mm) flux cored wire.

Gun Convenience Kits

- #234 607 .024 in (0.6 mm)
- #234 608 .030 in (0.8 mm)
- #234 609 .035 in (0.9 mm)

Each kit contains 10 contact tips, 1 nozzle and 1 contact tip adapter.

For Spoolmate™ 100 Series



Contact Tips (5 per package)

- #199 730 For .024 in (0.6 mm) wire.
- #186 419 For .030 in (0.8 mm) wire.
- #186 406 For .035 in (0.9 mm) wire.



Nozzle #186 405



Drive Roll (1)

#186 413

For .030/.035 in (0.8/0.9 mm) wire.



Push Roll (1)

#186 414

For .030/.035 in (0.8/0.9 mm) wire.

Typical Installations



**MIG (GMAW) or Flux Cored (FCAW)
Basic Equipment**

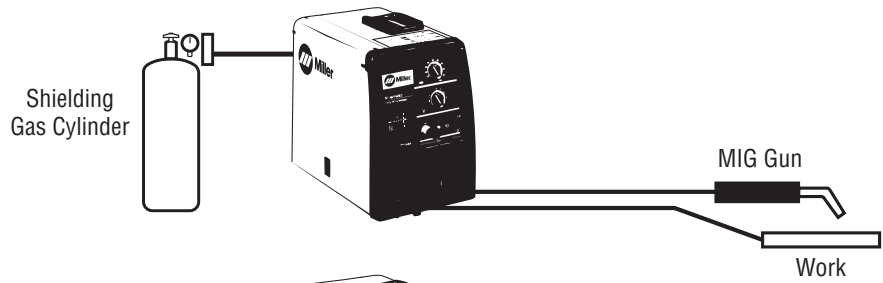

**Aluminum MIG (GMAW)
Basic Equipment**

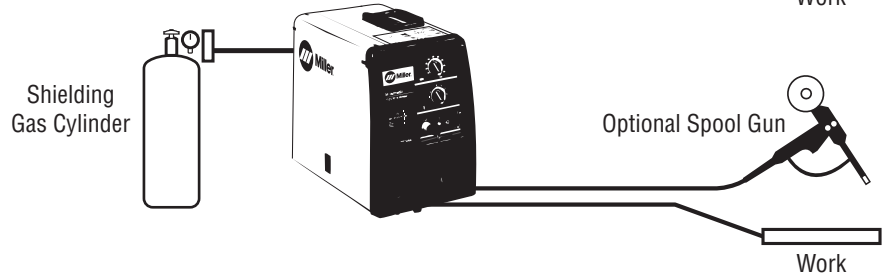

Ordering Information

Equipment and Options	Stock No.	Description	Qty.	Price
Miller [®] 211 Auto-Set [™] with MVP [™]	#907 422	120/230 V, 60 Hz		
Miller [®] 211 Auto-Set [™] with MVP [™] with Small Running Gear	#907 422-01-1	Power source packaged with #300 425 Small Running Gear/Cylinder Rack		
Guns				
Spoolmate [™] 100 Series Spool Gun	#300 371	Includes 12 ft (3.7 m) cable and custom carrying case		
M-10 Gun	#195 605	10 ft (3 m), .030–.035 in (0.8–0.9 mm)		
Consumables (Order from Miller Service Parts.)				
Contact Tips		See page 3		
Contact Tip Adapter		See page 3		
Replacement Liners		See page 3		
Nozzles		See page 3		
Spot Nozzles		See page 3		
Gasless Flux Cored Nozzle	#226 190			
Gun Convenience Kit	#193 973			
Drive Rolls		See page 3		
Accessories				
Running Gear/Cylinder Rack	#770 187			
Small Running Gear/Cylinder Rack	#300 425			
Protective Cover	#195 149			
CO ₂ Regulator/Flow Gauge	#237 702	Required if using 100% CO ₂ Gas. Order from Miller Service Parts		
Material Thickness Gauge	#229 895			
Flux Cored Wire				
Solid Wire				
Shielding Gas Cylinder				
Helmet/Gloves/Scratch Brush				

Date:

Total Quoted Price:

Distributed by:

